

PARK CITY SURVEYING  
 P.O. BOX 682993  
 PARK CITY, UTAH 84068  
 (435) 649-2918

DATE	BY	REVISIONS	COMMENTS

SURVEYED BY:  
GC/TM  
 DRAWN BY:  
MN  
 DATE:  
SEPTEMBER 2007

FOR: YARROW CORPORATION  
 DWS: YARROW ALTA.dwg  
**ALTA/ACSM LAND TITLE SURVEY**  
**1800 PARK AVENUE PARK CITY, UTAH**  
**BUILDING/VEGETATION DETAILS**

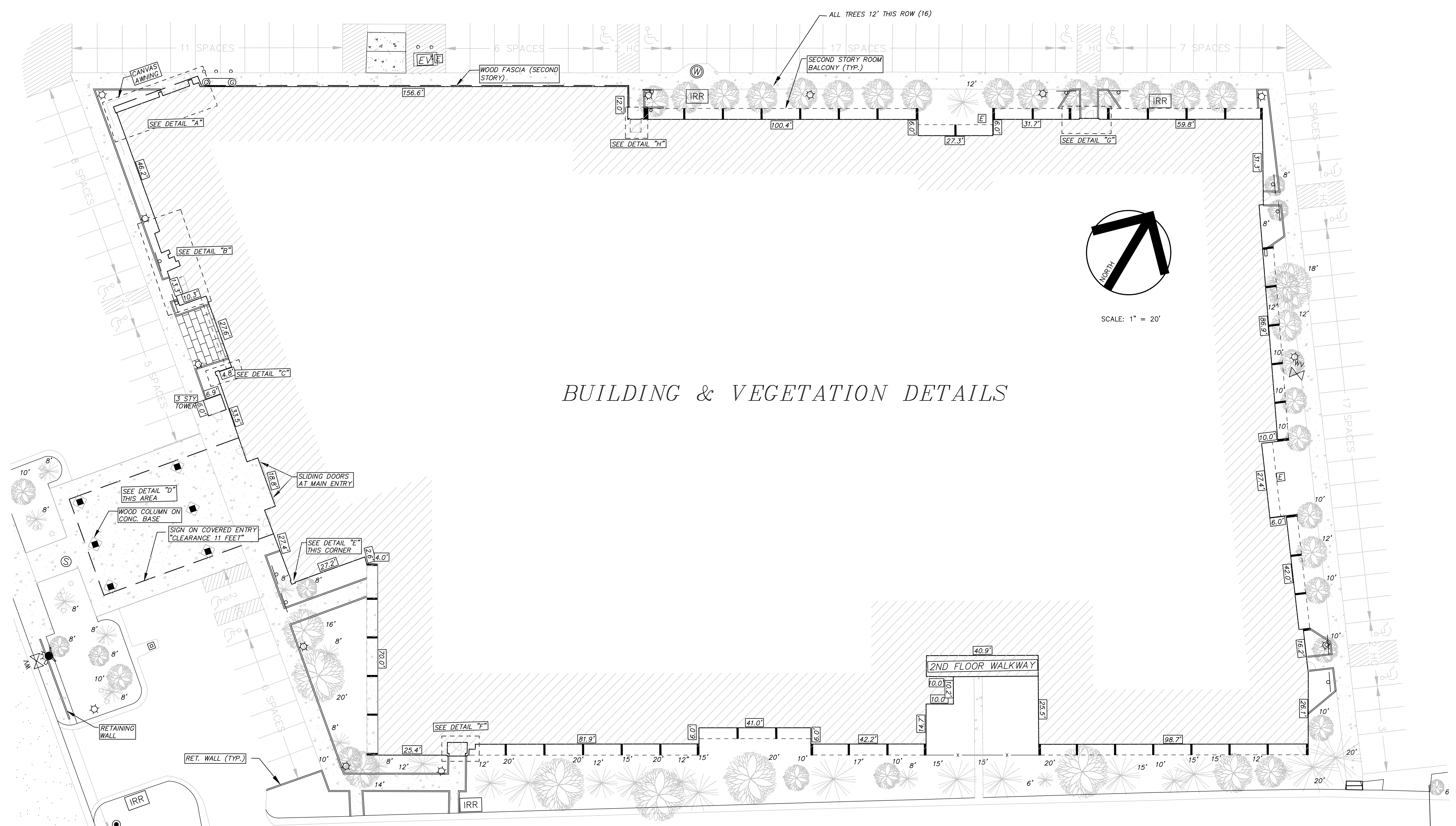

BUILDING & VEGETATION DETAILS

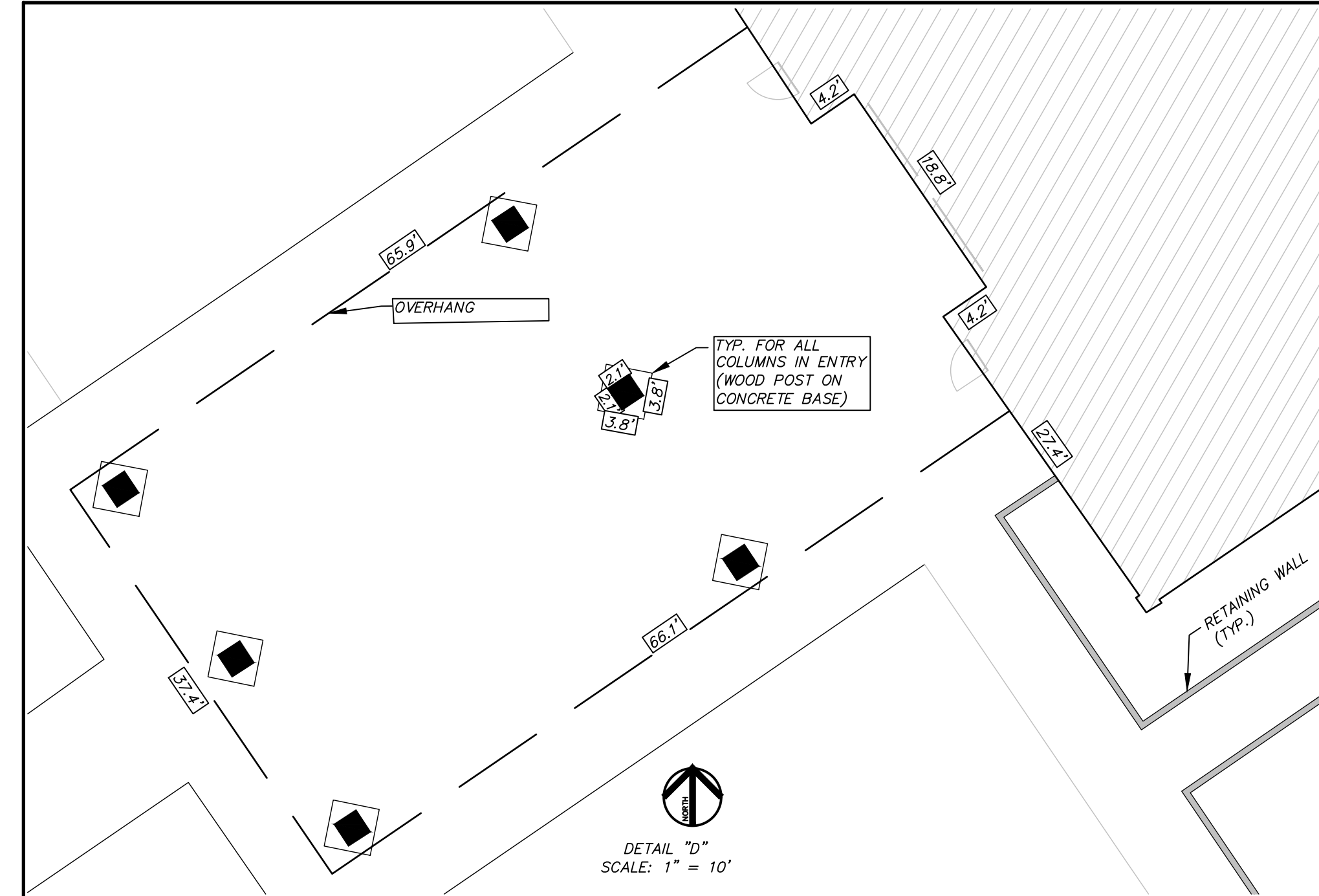
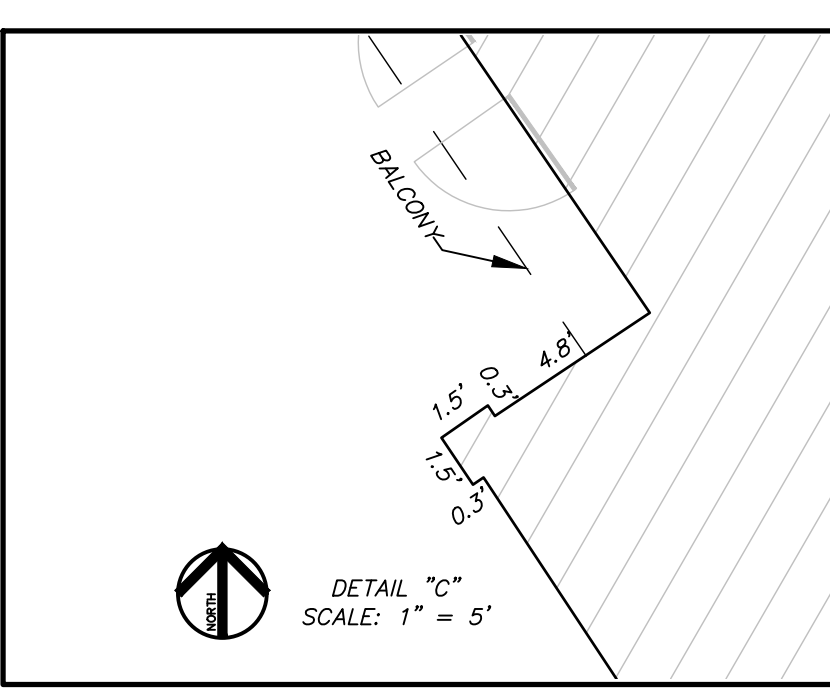
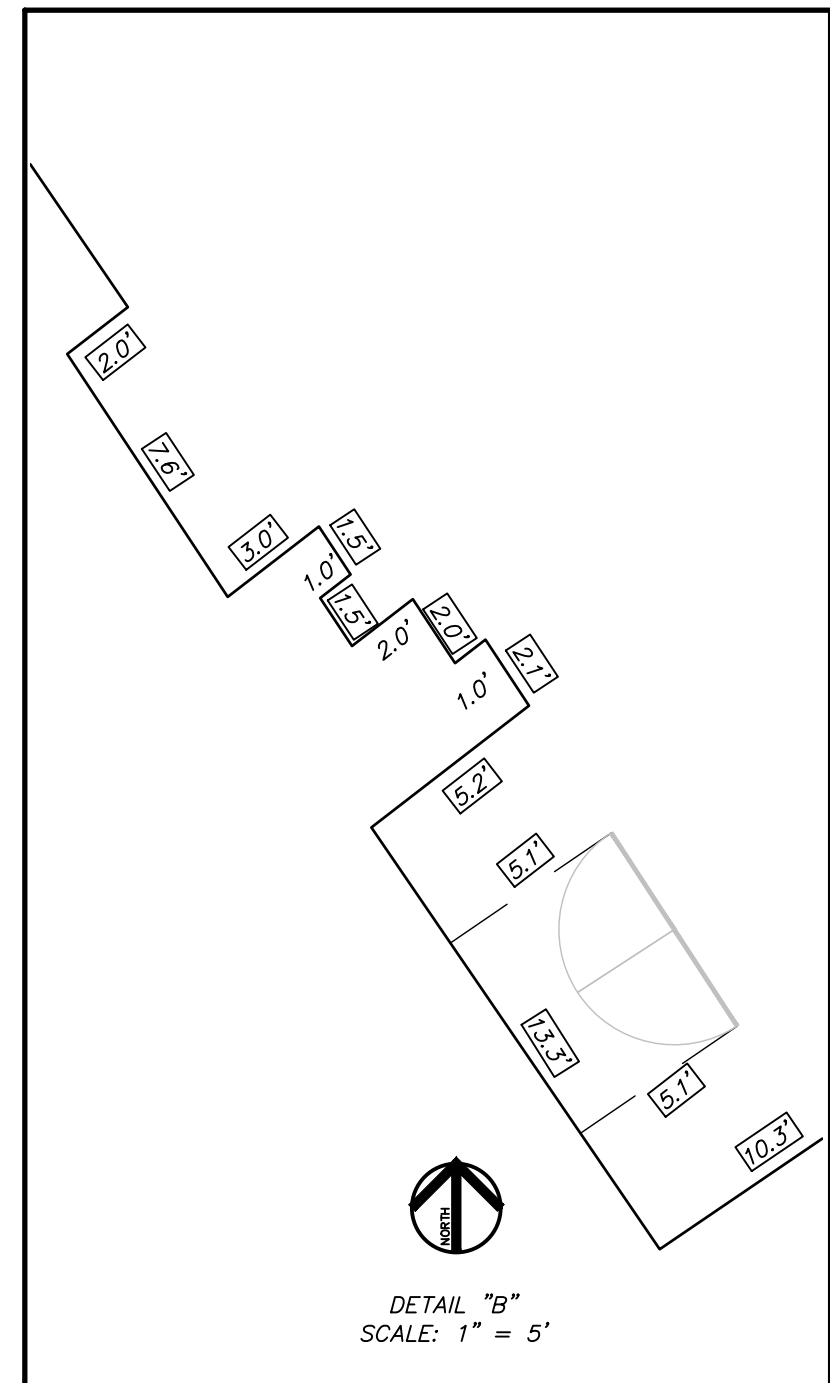
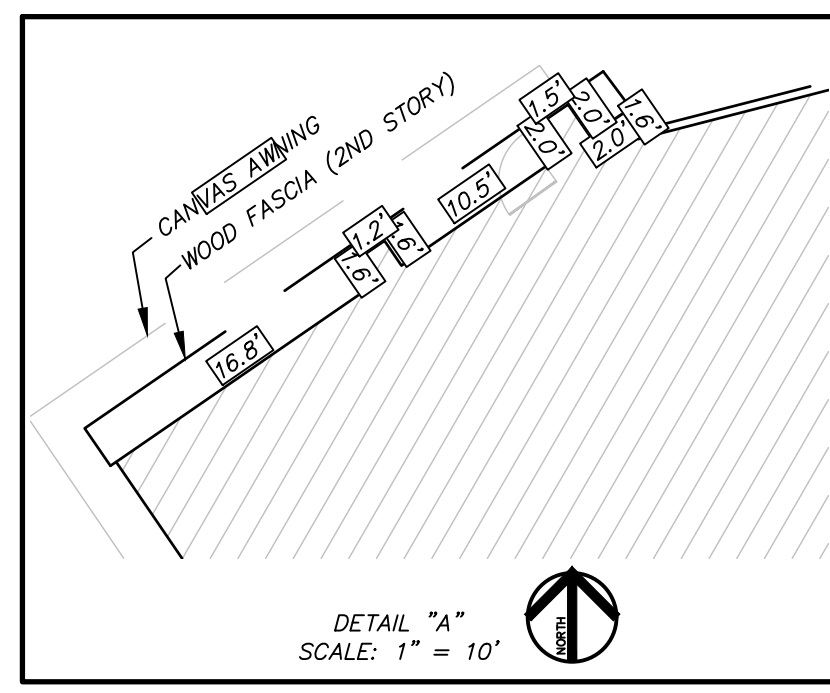

- LEGEND**
- ⊙ SANITARY SEWER MANHOLE
  - ⊞ ELECTRIC BOX OR OUTLET
  - ⊞ ELECTRIC VAULT
  - ☆ LAMP POST
  - ⊞ FLOOD LIGHT
  - ⊞ TELEPHONE PEDESTAL
  - ⊞ IRRIGATION BOX
  - ⊙ GAS METER
  - ⊙ GUARD POST
  - ⊞ GAS VALVE
  - ♿ HANDICAP PARKING SPACE
  - HC HANDICAP ACCESS
  - ▭ CURB INLET
  - ▭ CATCH BASIN
  - ⊞ SIGN
  - FENCE
  - ▬ 6" x 6" WOOD RETAINING WALL
  - TREE DIAMETER ANNOTATED TO EDGE OF DRIP LINE
  - ⊙ 12' CONIFEROUS TREE
  - ⊙ 12' DECIDUOUS TREE

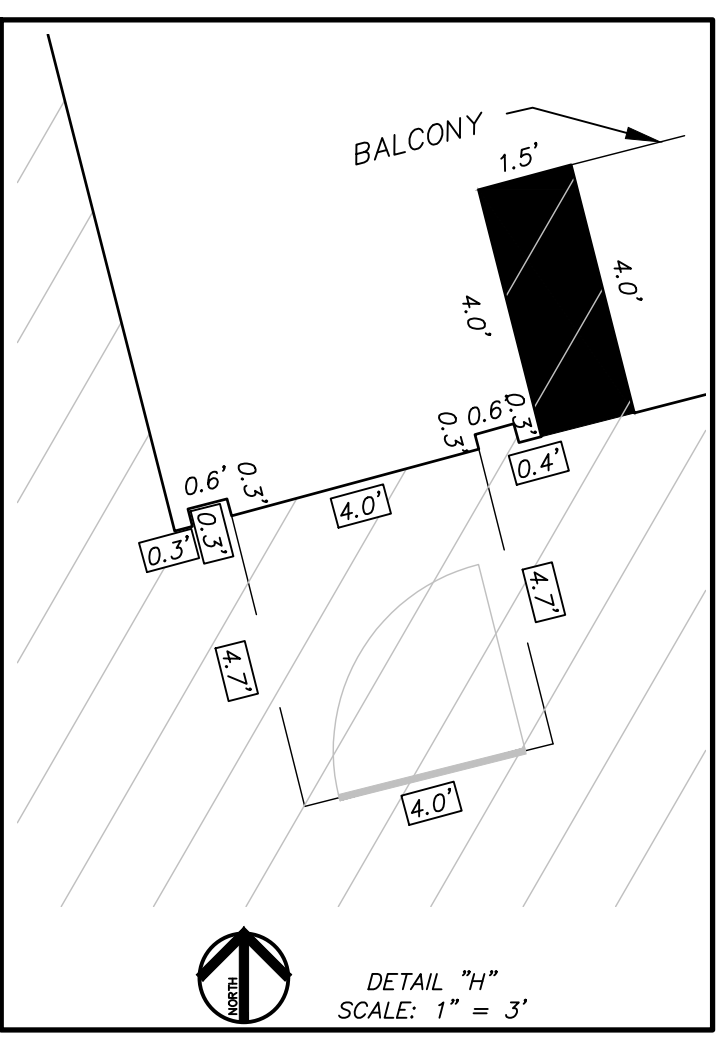
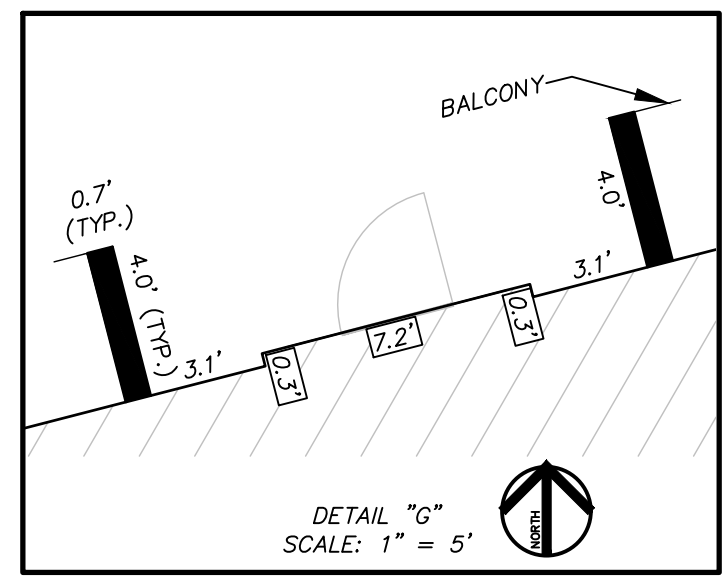
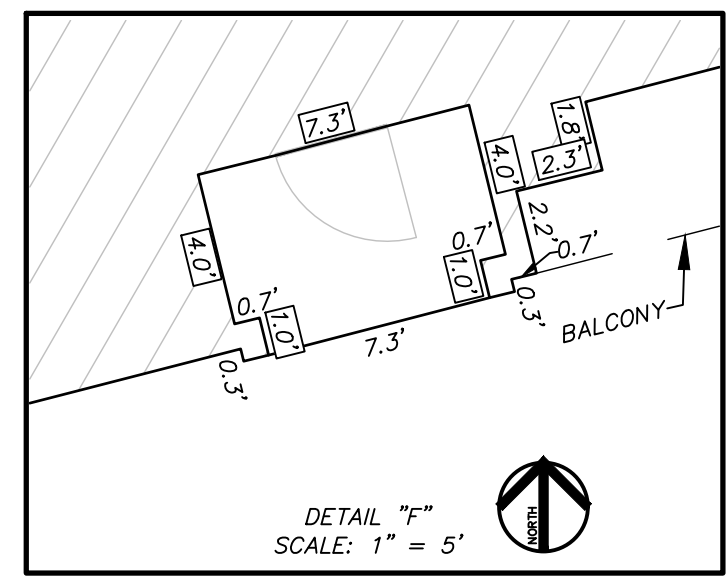
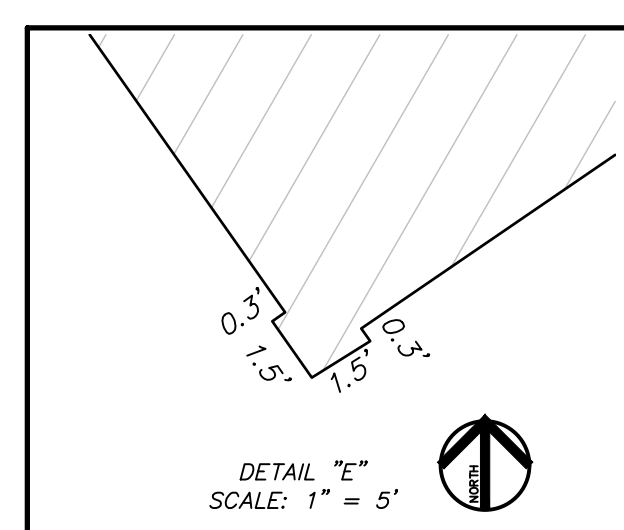

C:\Users\Owner\Dropbox (Park City Surveying)\Park City Surveying Team Folder\2Dme\PC\_MISC\YARROW ALTA.dwg, 6/20/2022 2:28:51 PM, AutoCAD PDF (General Documentation).pc3